

MANUAL SECTION	ISSUE DATE	AUTHORISED	REPLACES	PAGE
Flooring	Sept 2009	PM	July 2008	1 of 5

**SURESHIELD Heavy Duty floor Topping**

**DESCRIPTION:**

Sureshield is an industrial grade floor topping system specifically designed for the food industry. Sureshield resin is blended with specially graded silica quartz aggregates to produce a floor system that is hard and durable, Non-slip, resistant to impact, abrasion, thermal shock and chemicals/food acids, yet is non porous, seamless, hygienic and easily cleaned. Sureshield is fully bonded to the concrete to prevent water creep.

**TYPICAL PHYSICAL PROPERTIES/ FEATURES:**

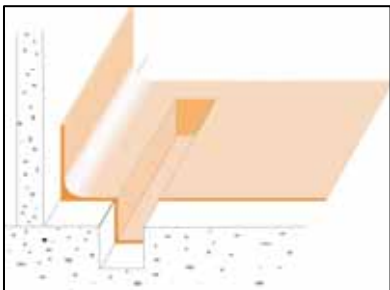

- Sureshield is a heavy duty monolithic 8-9mm thick floor topping.
- Rapid Cure: Full system may be installed within a 8hr period.
- Excellent chemical resistance. See chart.
- Excellent abrasion resistance (6 times that of basalt concrete).
- Excellent impact resistance:
- Excellent adhesion to properly prepared substrates.
- Easily cleaned. See comments at end. Waterblast resistant.
- Excellent slip resistance. Confirm degree required in specification.  
Steel trowel Finish: 0.46 ASTM3661.1  
Glass Float Finish: 0.58  
Aggregate Finish: 0.73
- Able to be formed into coving, plinths, sumps etc.
- Good resistance to thermal shock. When cured, will perform at all normal in-service temperature ranges. ie. Operational Freezers to hot & boiling water applications, as well as steam cleaning.
- Fire Resistant: AS/ISO 9239.1-2003: Non-directional.  
Critical Heat / Radiant Flux: 6.5Kw/m<sup>2</sup>  
Smoke Value: 379 Kw/m<sup>2</sup>
- Will not support bacteria or fungal growth. Contains STERISHIELD to retard microbial growth. See Tech bulletin.
- Cured film is non-toxic.
- Not moisture permeable.
- Moisture absorption: 0.04% as per ASTM D570-63
- Flexural strength: 25Mpa
- Weight per m<sup>2</sup> @ 8mm thickness: 17-18kgs
- Co-efficient of expansion 2.23 x 10<sup>5</sup>/C between 20°C and 60°C when heated at 1°/minutes.
- Minimum thickness: 8mm
- Minimum application temperature: +5°C
- Colour: Natural Gold; or other colours dependant on aggregate selection, or the system may be tinted for full thru-colour permanence.

**RECOMMENDED USES:**

- Meat works, abattoirs, butchery floors, bottling plants, breweries, food and beverage processing plants.
- Freezers, chillers, coolstores
- Dairy factory floors.
- Ablution blocks, kitchens, laundries. Supermarkets: Bakeries, Fish, Meat, deli etc
- Toilets, changing rooms, sports facilities for hard-wearability.
- Floors, walls, upstands, plinths etc where a high degree of chemical, mechanical and slip resistance is of prime importance.

No warranty either expressed or implied or statutory is made by NUPLEX in this document except as expressly stated in any sale and purchase agreement entered into between NUPLEX and the buyer. CERTIFIED ISO 9001 REG. NO. 158 This document is a technical data information sheet The description of the product or products and the properties of the product or products contained in this document is for the sole purpose of identifying the product or products and describing their property or properties and does not constitute a warranty that the product or its properties shall conform to that description; nor is the description of the product and/or its properties a warranty by NUPLEX that the goods are suitable for a particular purpose.

## **SURESHIELD** (cont'd)

- Food process floors where a high degree of hygiene is required. Approved by regulatory authorities.
- Interior/exterior use. Concrete repair and protection – resurfacing damaged or broken concrete with a more physical and chemical resistant surface.
- Can be applied to new or existing sound concrete, timber or other surfaces.
- Suitable for use in dry or wet situations including ramps.
- Will form coves to any required height or radius.
- Floors above work spaces: Sureshield forms a watertight barrier and is compliant with E3 Internal water 3.1.1e. (use full fibreglass laminated floor and Joint safe tape in these situations).

### \*\*\*\***Note**\*\*\*\*

Special treatments may be required on some ramps in **wet** situations in order to comply with slip resistance requirements of AS/NZ 3661.1:1993. Specific advice must be sought from Nuplex Industries Ltd, Construction Products Division prior to specifying in this situation. See page 1

### **LIMITATIONS:**

- Application to uncured concrete (minimum recommended cure 28 days). Application to damp surfaces. (Refer to Nuplex Bulletin on application options on wet or uncured concrete).
- Application to unstable or defective substrates without approved remedial treatment prior to installation.
- Application below +5C.
- Application where fumes may contaminate adjacent foodstuffs (refer to Nuplex Supascreed or Nuthane for odour free installations). This only applies in the installation stage (up to 3 hrs after laying).
- Application over existing coatings/toppings – refer to Nuplex.
- Over concrete cure or release agents without Nuplex approval.
- Over ceramic tiles without specific written Nuplex design specification.
- Refer to Nuplex chemical resistance data.

## **CHEMICAL RESISTANCE CHART 2009**

Test procedure involves total immersion of the polymerized sample in a test medium at 25 Deg C. The sample were observed for chemical attack and hardness throughout the testing period. The results below were taken after 3 weeks exposure:

<b>Test Media</b>	<b>conc.</b>	<b>Sureshield</b>
<b>ACIDS</b>		
Hydrochloric Acid	10%	M
Sulphuric Acid	10%	M
	25%	U
Acetic Acid	10%	M
	50%	M
Nitric Acid	10%	M
Citric Acid	10%	M
Lactic Acid	90%	M
Phosphoric Acid	30%	M
<b>ALKALIS</b>		
Potassium Hydroxide	30%	A
Caustic Soda	50%	A

<b>SOLVENTS</b>		
Ethanol		M
Toluene		A
Acetone		D
Isopropanol		U
<b>PETROCHEMICALS</b>		
Kerosene		U
<b>DISINFECTANTS &amp; CLEANERS</b>		
Detergent (DET 18)	100%	U
Bleach (2.5% Sod Hyd Cl)		M
MEKP - M50		A
<b>SALT SOLUTION</b>		
Brine	20%	U
<b>OTHERS</b>		
Sugar Syrup	30%	U
Distilled Water		U

### **LEGEND**

- U = Unaffected (i.e. after 3 week exposure the samples have not changed)  
M = Marked (Short term exposure, the test media will leave a mark on the sample)  
A = Attacked (Short or long term exposure, the mechanical properties will deteriorate)  
D = Destroy (Short or long term exposure, damage will occur)

## **SUBSTRATES**

All substrates shall be stable and solid.

**Note:** The ability of new or existing floors to take the loads as a result of the Nuplex Sureshield must be checked prior to installing. All control joints junction cracks in the substrate etc are to be properly treated . Nuplex Industries should be consulted when installing Nuplex Sureshield on any suspended floor slabs.

### **CONCRETE**

Shall have a surface which has been mechanically trowelled to AS3610:1995 U3/NZ/3114:1987U3 finish or . Then preparation is achieved by captive shot blasting or other coarse abrasive methods. Eg Diamond grinding. Concrete shall be cured for a minimum of 28 days prior to laying Sureshield. The moisture content shall be less than 75% RH. (Refer Nuplex Bulletin on application options on wet or uncured concrete).

**Plywood or Timber:** consult Nuplex for information

Note: If the substrate is an above grade slab and waterproofing is required to comply with NZBC E3, the tank the floor and cove upstands with a layer of 450gsm CSM fibreglass. This will provide a seamless waterproofing layer.

Ensure the floor is clean, dry and prepared as above.

Install Nuplex **cove** upper termination metal strips: **5.2mm, 8.8mm or 9.2mm rebated strip** are available (see separate details drawings). Use a rebated wall cut (see details) if the coving strip cannot be used.

Install fibreglass CSM cloth in floor wall internal corners.

Prime the properly prepared floor areas with minimum one coat of STZ Primer. Coverage rate and number of coats will vary depending on the porosity of the substrate, Maximum coverage 6m<sup>2</sup>/litre/coat. STZ Primer and STZ Hardener are to be thoroughly mixed in the correct proportions (1-3% on STZ Primer weight).

Wait until STZ Primer has gelled/set before overcoating.

## **PREPARATION**

## **APPLICATION:**

Nuplex Sureshield must be applied in such a manner to achieve a minimum 8mm thickness. Use screed box, bars or install angle strips as a guide. Accurately weigh and power mix until homogeneous Nuplex Sureshield Resin and STZ Hardener in the correct proportions:

	Approximate M <sup>2</sup> coverage
Nuplex Sureshield Resin	3.5 kgs
Nuplex STZ Hardener (on Sureshield Resin weight).	1-3%

Add selected Nuplex Blended Sand at the ratio:

<b>Floors</b> - Nuplex STZ Floor Sand	21kgs
<b>Coves</b> - Nuplex STZ Cove Sand	21kgs

Note: Maximum Sureshield Resin:Filler (sand) ratio 1:6 parts by weight Resin, Hardener and Sand are to be blended in an efficient mixer to ensure all ingredients are homogenously blended.

Apply Nuplex Sureshield flooring to correctly prepared and sealed substrate using a spreader box and/or a suitable glass, steel trowels, power float etc. Ensure the matrix is well compacted and free of ridges or unevenness. Successive mixes must be homogeneously blended together into wet Nuplex Sureshield mixes. Access to repair wet floor areas during installation can be achieved using crampons or special spiked shoes. Adequate lighting is to be provided to ensure defective surface finishing can be easily identified and corrected during the installation process. Lubricate tools and equipment used during the installation with sparing quantities of Styrene Monomer. Use Acetone only to clean tools and equipment.

**NON-SLIP floor definitions:** The contractor shall ensure that the surface finish, in all zones, is agreed with the client and samples supplied and agreed.

1. Smooth –steel trowel floated.
2. Non-slip & Hardwearing – glass float.
3. Heavy duty non-slip – glass float and the broadcast 18/36 non-slip aggregate into the wet surface. Follow this with roller applied topcoat.
4. Very sharp non-slip: glass float and the broadcast 18/36 mixed 50/50 with Silicon carbide non-slip aggregate into the wet surface. Follow this with roller applied topcoat.
5. Ensure the contractor supplies info on the above. and a cured sample showing the surface finish.

Ensure all finished edges of the Nuplex Sureshield are supported to avoid damage. Nuplex Sureshield may be applied to skirtings, coves and upstands if required with the use of Nuplex STZ Coving Resin and specially formed trowels. Optional coves and skirtings can be completed as the main floor is installed however they are best installed following installation of the floor. Floors must be protected during cove/skirting installation.

**Topcoat:** Once finished and hardened apply 1 coat of Nuplex STZ Topcoat at a spread rate no greater than 6m<sup>2</sup>/litre/coat. Topcoat must be applied only to clean and dry surfaces.

Optional: For greater Chemical resistance use Surechem VE topcoat applied at 3m<sup>2</sup>/lt in place of the STZ topcoat

**Joints:** All concrete control and construction joints should be carried through the Sureshield using C81 for movement joints and K130 Epoxy Gold for control joints. Use k130 for larger joints.

**Sample details**

For more details see the website: [resin floors / industrial toppings / "cove and install details"](#) for more options.

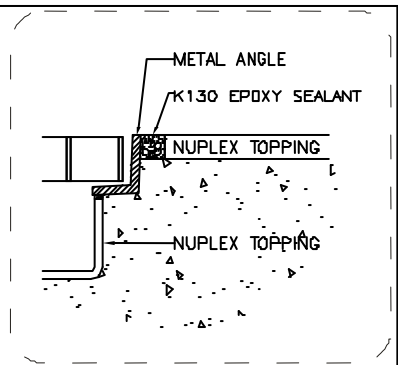
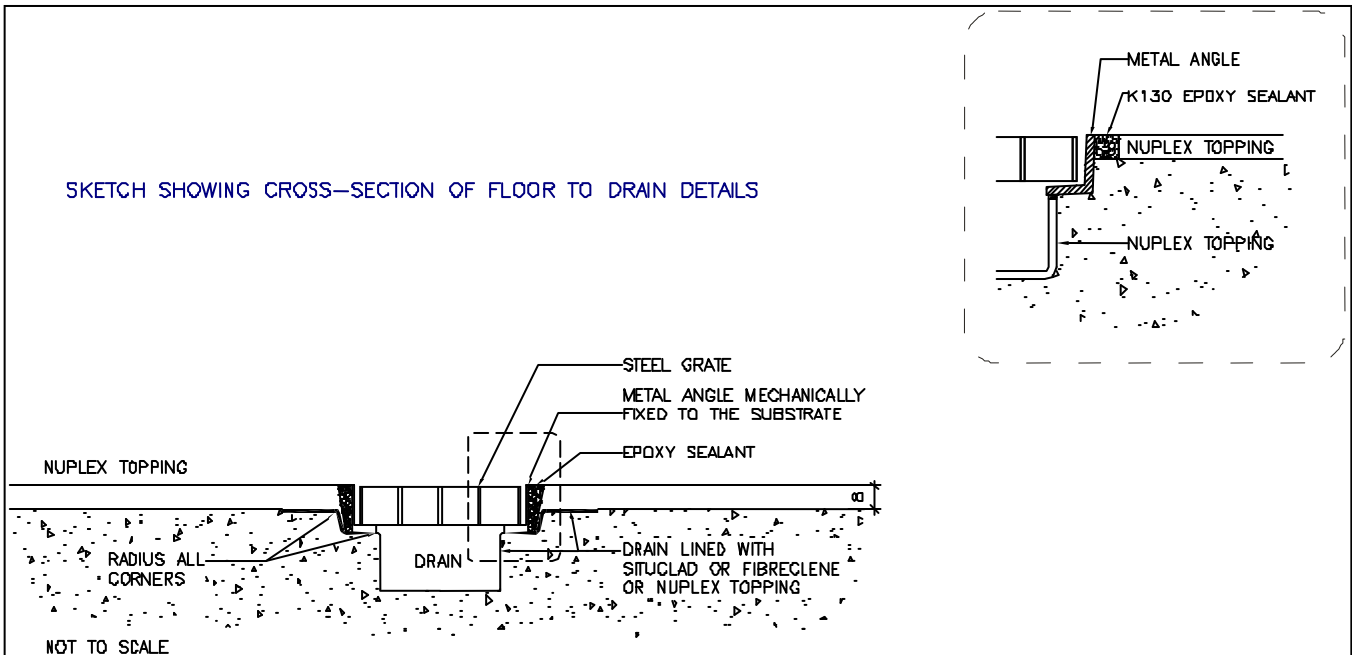
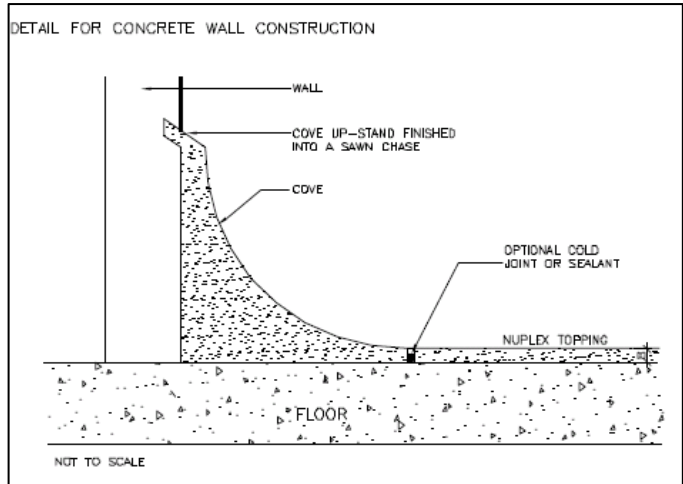
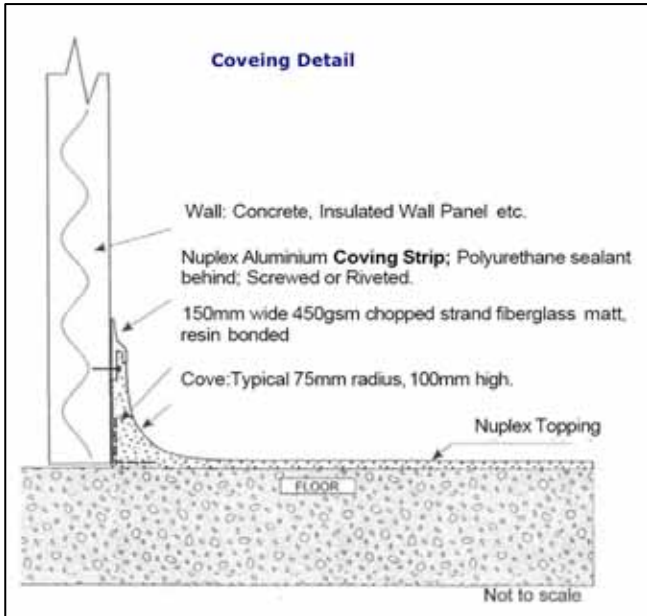

## **SURESHIELD** (cont'd)

### **QUALITY ASSURANCE:**

A log shall be kept by the licensed Nuplex Sureshield contractor and made available to Nuplex Industries Ltd at their request. Information to be recorded daily is:

1. Material batch numbers used.
2. Sequence of mixing, ratios and quantities and formula.
3. Substrate moisture content.
4. Substrate temperature.
5. Ambient temperature.
6. Ambient relative humidity.

### **THINNING cleanup:**

Do not thin. Lubricate tools with styrene monomer (mixer and barrows). Cleanup with acetone.

### **CURE AND DRY TIMES:** (25°C 50% RH)

Workable pot life:	20-30 minutes
Hard Dry:	3 hours
Light foot traffic:	3 hours
Recoat:	within 24 hours
Full Use:	4 hours

### **HEALTH & SAFETY:**

- Overalls are recommended when using this product. Wear gloves if this suits the user as the material will bond strongly to skin. It has not been found to be dermatitis causing.
- Fumes may be cloying in enclosed areas. The use of fans to provide positive forced air draft and/ or extraction is recommended. The levels of fumes have been shown to be well below recommended levels. See our data on emissions on our web bulletin board.
- Flammable 3C. Erect "No Smoking" signs. No welding or naked flames permitted during installation. Have fire extinguishers readily available.

### **SHELF LIFE:**

6 months in unopened containers. After this period suitability for use should be checked in consultation with Nuplex Industries Ltd. Sureshield is provided in both winter & Summer cure rates.

### **Complementary Materials:**

- Fibreclene smooth wall lining material to meet Sureshield above coving.
- Nuplex coving strips to form cove top termination.
- Surechem VE Topcoat to provide increased chemical resistance.
- Nuplex coloured aggregates and colorants to provide alternatively coloured floors.

### **Maintenance and Cleaning**

**Resurfacing:** Nuplex recommend two options: Re-aggregating with Traxite VE which is a high durability and chemically resistant finish. It offers very good adhesion to the prepared older surface. A second option is Nuthane topcoat which offers a monolithic and non-slip coloured finish with no odours.

**Repairs** can be undertaken with further new Sureshield applied directly or use K20 repair system.

**Cleaning:** A Sureshield floor is cleaned with stiff bristled brushes and detergents. The stiff bristle brushes and commercial detergents will remove dirt from the non-slip surface that a soft mop will not. The waxed nature of our topcoating system may attract dirt during the early life of the product. Pay careful attention to cleaning at this stage. Refer to the Cleaning document on our website.

### **Producer Statement**

Nuplex Industries Ltd state that Sureshield is compliant with E3 (internal water) and D1 (Access routes / slip resistance wet & dry).

**How to select Nuplex Floor toppings**

August 2009



**High performance Resin Flooring Choice Guide**

Nuplex manufacture in NZ a range of rein floorings. Some are more suitable than others depending on the installation parameters and the performance required within its applied environment.

	Original Construction	Internal work or reconfiguration. Isolated environment	Internal work or reconfiguration. Sensitive or Exposed Public area
General small commercial kitchen	Sureshield *2	Sureshield	Supascreed
Supermarket - Deli	Sureshield	Sureshield	Supascreed
Supermarket - Fish	Sureshield	Sureshield	Supascreed
Supermarket - Butchery	Sureshield	Sureshield	Supascreed
Supermarket - Bakery	Sureshield	Sureshield	Nuthane
Laundry	Sureshield	Sureshield	Supascreed
Hot cook – heat, oils fats	Sureshield	Sureshield	Nuthane
High impact processing	Sureshield	Sureshield	Sureshield*

- \* Protect area to enable use of this system for maximum durability.
  - \*2 Industrial Terrazzite and Sureshield are interchangeable.
- Trowel-on systems such as Sureshield offer:
- One-pass rapid installed flooring
  - Integrated floors, coves, drains, nibs and upstands
  - Carefully managed falls to drains to help prevent ponding water
  - Highest impact and abrasion resistance combined with high heat and chemical resistance
  - Best value for money on a dollars per mm thickness basis

